

AKAI

ENERGY

PROTECT YOUR WARRANTY

This unit must be installed by a registered,
licensed installer as required by
Government regulations.



5 kW Home Battery

Installation Manual

Model Number AKE-5KW-HB

Contents

| | |
|-----------|--------------------------------------|
| 03 | Important Safety Information |
| 06 | Product Overview |
| 10 | Getting Started |
| 11 | Installation |
| 21 | Display Interface |
| 26 | Communication Connection |
| 27 | Monitoring Software Interface |
| 33 | Operations |
| 35 | Troubleshooting |
| 37 | Maintenance |
| 39 | Other Useful Information |
| 49 | Installer Notes |

Important Safety Information

IMPORTANT SAFETY INSTRUCTIONS READ CAREFULLY AND KEEP FOR FUTURE REFERENCE

Read this manual thoroughly before first use, even if you are familiar with this type of product. The safety precautions enclosed herein reduce the risk of fire, electric shock and injury when correctly adhered to. Keep the manual in a safe place for future reference, along with the completed warranty card, purchase receipt and carton. If applicable, pass these instructions on to the next owner of the appliance.

Always follow basic safety precautions and accident prevention measures when using an electrical appliance, including the following:

WARNING: Electric shock hazard - professional installation only!

- This appliance must be professionally installed to an appropriately earthed wiring system by a licensed installer, following the instructions in this manual.
- Ensure to make these instructions available to the installer. Failure to install the appliance correctly could invalidate any warranty or liability claims.
- Alterations to the domestic wiring system must only be made by a qualified electrician. Failure to follow this advice may result in electric shock or death.

General usage conditions and restrictions

- **Installation location:** This battery is designed for indoor use only.
- **Installation parameters:** This battery must be wall-mounted at least 1 m away from the floor, and at least 50 cm from any walls or other batteries. It must be installed in the shade, at least 5 m away from any heat source.
- **WARNING! This equipment is not suitable for use in locations where children are likely to be present.**
- **Intended purpose:** Only use this battery for its intended purpose, in its intended environment and as described in this manual. Any other use may cause fire, electric shock or injury.
- **Follow instructions:** Make sure to observe all rules and provisions in this manual. These instructions are not intended to cover every possible condition and situation. As with any product such as this, use common sense and caution when installing, operating and maintaining.

Electrical Safety

- **WARNING! High Voltage:** Any object - particularly a wet object - coming into contact with a high voltage power supply (directly or indirectly) can cause serious injury or death.
- **Tools:** When working with high voltage and AC power, be sure to only use the required, special-purpose tools.

Important Safety Information (Cont.)

- **Static electricity:** Any static electricity could damage veneer on the electrostatic sensitive components. Before touching the plug in, circuit board or chips, be sure to use correct electrostatic prevention measures.
- **WARNING! Power supply:** When installing or maintaining this battery, the power supply must be disconnected first.
- **Short circuit:** The power system provides a DC regulated power supply. DC short circuit could cause serious damage to the equipment.
- **Battery top:** Do not rest any items on top of the battery.
- **CAUTION! Charging temperature range:** The temperature range at which the battery can be charged is -10°C to 50°C . Charging the battery at temperatures outside of this range may cause damage to the battery and/or its surroundings. Charging the battery outside of this temperature range may also harm the performance of the battery or reduce the battery's life expectancy.
- **CAUTION! Discharging temperature range:** The temperature range at which the battery can be discharged is -20°C to 45°C . Use of the battery outside of this temperature range may damage the performance of the battery or may reduce its life expectancy.
- **DANGER! Discharging device:** Do not discharge the battery using anything other than the specified device. When the battery is used in devices aside from this, it may damage the performance of the battery or reduce its life expectancy. Additionally, if the device causes an abnormal current to flow, it may cause the battery to become hot and cause serious injury.
- **WARNING! Hazardous Voltage:** The battery system operates with hazardous voltages. Installation, maintenance and repairs must ONLY be carried out by qualified personnel.
- **DANGER! Battery Cells:** Even after the unit is disconnected from the mains, components inside are still connected to the battery cells which are potentially dangerous.
- **WARNING! Disconnecting:** Before carrying out any kind of service and/or maintenance, disconnect the batteries and verify that no current is present and no hazardous voltage exists in the terminals.
- **WARNING! Authorised personnel:** Only persons that are adequately familiar with batteries and with the required precautionary measures may replace batteries and supervise operations. Unauthorized persons must be kept well away from the batteries.

Important Safety Information (Cont.)

- **DANGER! Battery terminals:** Verify that no voltage between the battery terminals and the ground is present before maintenance or repair. In this product, the battery circuit is not isolated from the input voltage. Hazardous voltages may occur between the battery terminals and the ground.
- **WARNING! Metal items:** Batteries may cause electric shock and have a high short-circuit current. Please remove all wristwatches, rings and other metal personal objects before maintenance or repair, and only use tools with insulated grips and handles for maintaining or repairing.
- **WARNING!** An overcurrent and disconnection protection device must be installed between the battery and the inverter.
- **WARNING! Replacements:** When replacing the batteries, install the same number and same type of batteries.
- **WARNING! Parallel:** When replacing the parallel batteries, make sure the new battery is full charged.
- **WARNING! Do not open or destroy batteries.** Escaping electrolyte can cause injury to the skin and eyes. It may be toxic.
- **WARNING! Fuse:** Please replace the fuse only with the same type and amperage in order to avoid fire hazards.
- **WARNING! Disassembly:** Do not open or disassemble the battery system.

Please see pages 39-44 for more information on the specifications and parameters of this battery.

Product Overview

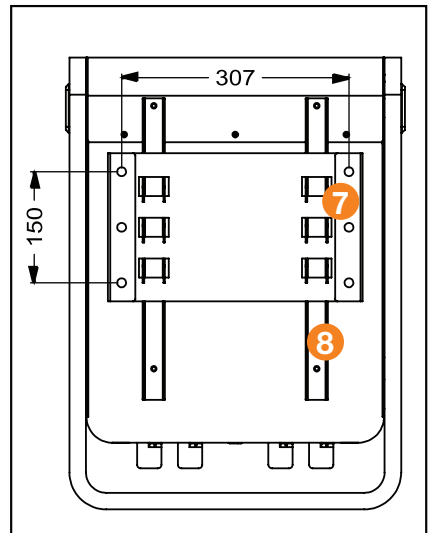
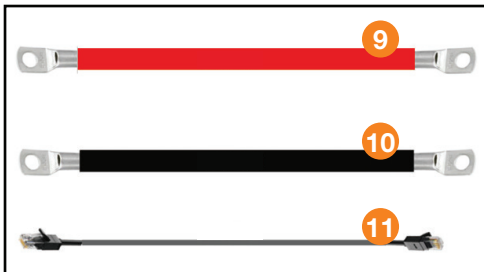
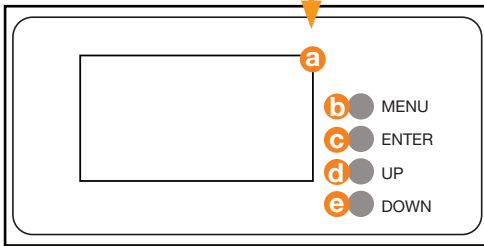
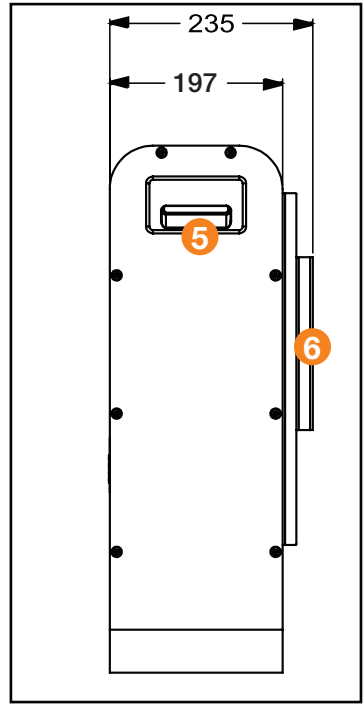
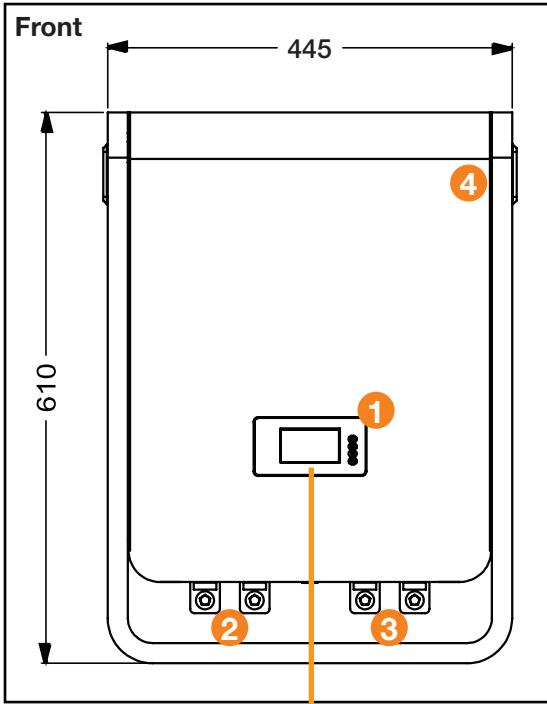

Product Overview (Cont.)

Scope of delivery

A Parts list

- 1 Control panel
 - a Display
 - b MENU button
 - c ENTER button
 - d UP button
 - e DOWN button
- 2 Positive Terminals (Cathodes) (red)
- 3 Negative Terminals (Anodes) (black)
- 4 Battery housing
- 5 Handle
- 6 Wall-mounting bracket (side view)
- 7 Wall-mounting bracket (back view)
- 8 Bracket

B Accessories

- 9 Red power cable (2000 mm)
- 10 Black power cable (2000 mm)
- 11 Communication cable (2000 mm)

C Documentation (not shown)

Installation manual

Data sheet

Warranty certificate

NOTE: All measurements are in millimetres.

NOTE: Due to continued product improvement, images and illustrations in this manual may vary slightly from the product purchased. All images in this manual are for reference purposes only. Parts are not necessarily pictured to scale.

Product Overview (Cont.)

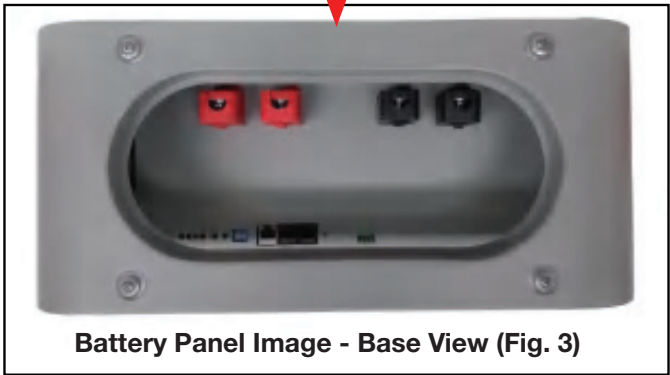

Battery Panel Image - Base View (Fig. 3)

Product Overview (Cont.)

Battery Panel Diagram (Fig. 4)

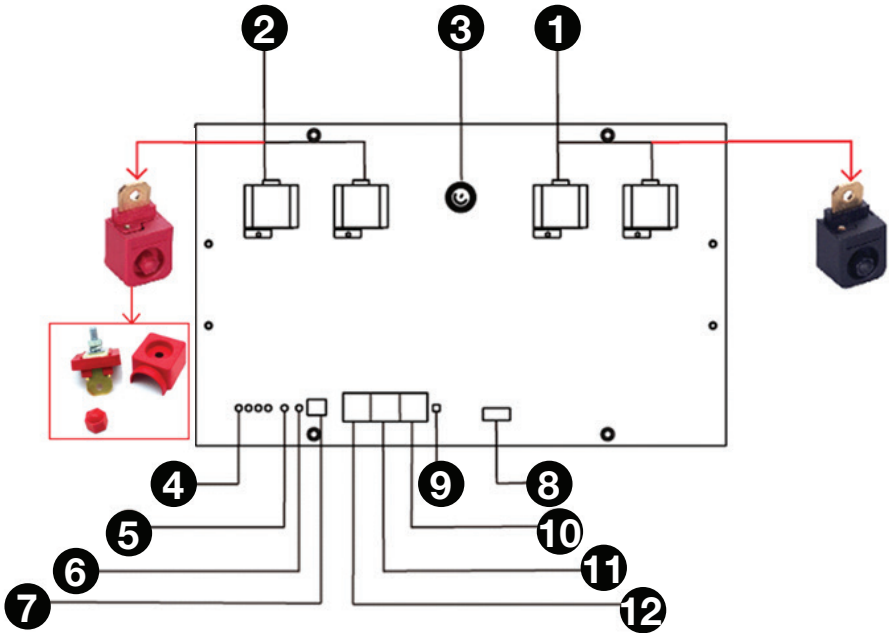

| No. | Description | Functional Description |
|-----|--|--------------------------------------|
| 1 | Battery - | Negative terminal (Anode) |
| 2 | Battery + | Positive terminal (Cathode) |
| 3 | POWER | BMS switch |
| 4 | Display the battery's capacity | Electricity volume indicator |
| 5 | Display state information | ALM alarm indicator light blinking |
| 6 | Running light | Run indicator light ON |
| 7 | Display connection address | ADS Dialer |
| 8 | Dry Contact | Charge/Discharge Dry Contact |
| 9 | Reset key | |
| 10 | RS-485 connection port-A RS485/ CAN | RS485/CAN communication interface |
| 11 | RS-485 connection port-B RS485/ CAN | RS485/CAN communication interface |
| 12 | RS-232 connection port RS232 | RS232 to PC |

Getting Started

Unpacking

- This product has been packaged to protect it against transportation damage. Unpack the battery and lay out the separate components. Keep the original packaging carton and materials in a safe place. It will help prevent any damage if the product needs to be transported in the future. In the event that the packaging materials are to be disposed of, please recycle them where possible.
- Plastic wrapping can be a suffocation hazard for babies and young children, so ensure all packaging materials are out of their reach and disposed of safely.
- Inspect the home battery for visual damage. Unwind the cords to their full lengths and inspect them for any damage. Do not use the appliance if the appliance or its cord have been damaged or are not working properly, or if any parts are missing (see page 7 for a full list). In case of damage or missing parts, contact our after sales support centre for advice.
- Make sure you have read and understood all instructions and warnings in this manual. Refer to the Product Overview, pages 6–9, to familiarise yourself with the product and identify all parts. Pay particular attention to the safety instructions on the previous pages.

IMPORTANT!

Installation and wiring must be completed in accordance with local electrical laws and regulations. **This battery MUST be installed by a qualified professional.**

WARNING!

- Make sure the main wire is in compliance with the standard of rated capacity of the battery to avoid hazards like electric shock or fire.
- Do not use the wall receptacle as the input power source for the battery, as its rated current is less than the battery's maximum input current. Otherwise the receptacle may be burned and destroyed.

Installation

Diagram of system

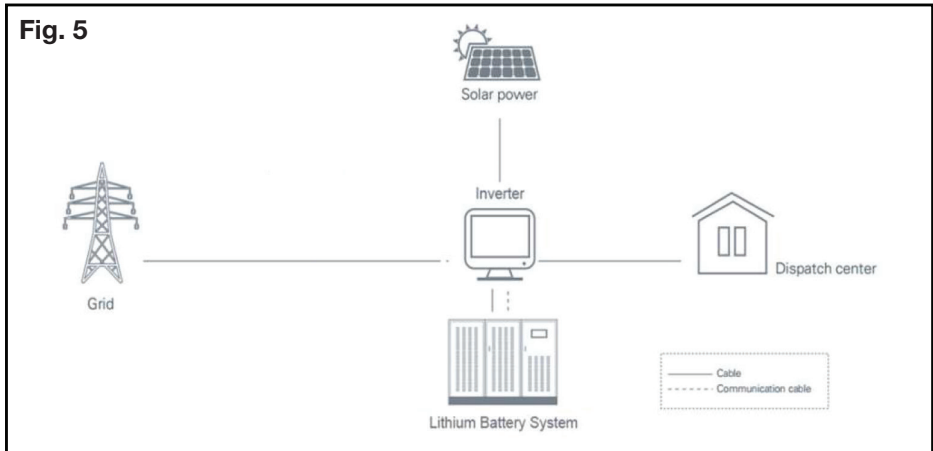

This system works through connection with solar panels and the grid. Firstly, your solar panels generate energy from the sun in the form of DC electricity. This then flows through an inverter, which converts the DC electricity into AC electricity for use in the home. Any extra electricity that is not being used is then stored in your AKAI Energy 5 kW Home Battery/Batteries. Then, when there is no sun, your home can be powered using the saved energy. This system is also connected to the grid, in case there is no sun and your battery is depleted, to ensure your home always has access to electricity.

System Installation

IMPORTANT!

Installation and wiring must be completed in accordance with local electrical laws and regulations. **This battery MUST be installed by a qualified professional.**

WARNING!

- Make sure the main wire is in compliance with the standard of rated capacity of the battery to avoid hazards like electric shock or fire.
- Do not use the wall receptacle as the input power source for the battery, as its rated current is less than the battery's maximum input current. Otherwise the receptacle may be burned and destroyed.

Installation (Cont.)

Installation Location

- The installation location of this product is key. It should be installed indoors in a location that can be accessed conveniently for maintenance purposes. The installation location should also allow for sufficient space for pedestrian passage.
- This equipment is not suitable for use in locations where children are likely to be present.
- This appliance should only be installed on a sturdy wall that is strong enough to support its weight (52.68 kg). It should be installed using the included bracket and appropriate screws and tools.
- There should be sufficient room between the battery/batteries and any other objects. The battery should be installed at least a metre above the floor, and at least 50 cm away from any walls (aside from the wall that it has been mounted on), or other batteries. It should be installed at least 5 m away from any heat sources.
- During installation, avoid placing the battery in the direct sunlight or near the heat source, and avoid any air conditioner opening directly facing the battery pack. During installation, ensure that sufficient maintenance space is reserved between the battery packs, and ensure that your battery is in a clean, dry and well ventilated area.

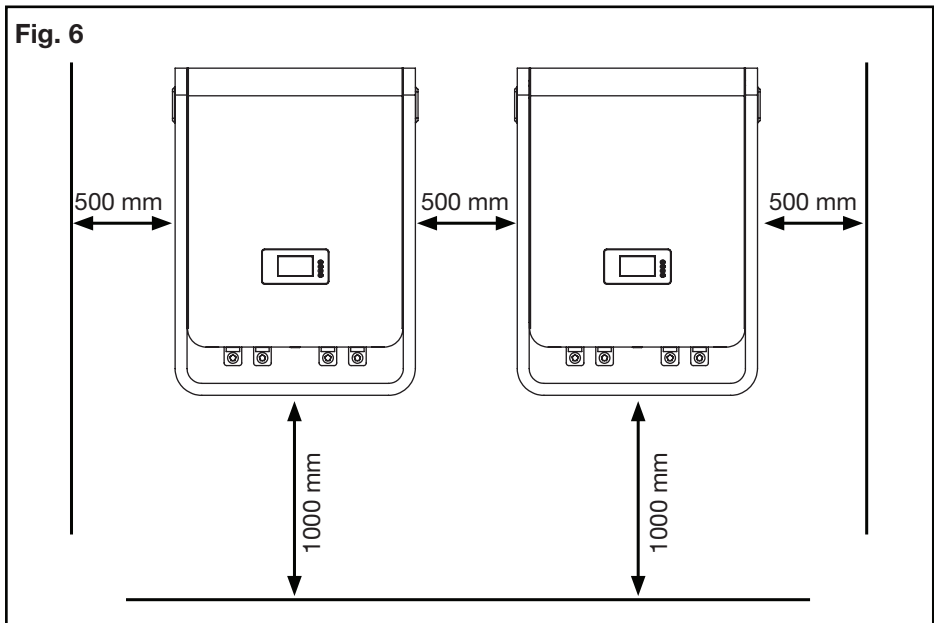

NOTE:

- Batteries **MUST** be installed indoors.
- Batteries **MUST** be installed at least 5 metres from any heat source.
- Batteries **MUST** be installed in a shaded area.

Installation (Cont.)

Installation Procedure

WARNING! Make sure the main wire is in compliance with the standard of rated capacity of battery to avoid hazards like electric shock or fire.

WARNING! Do not use the wall receptacle as the input power source for the battery, as its rated current is less than the battery's maximum input current. Otherwise the receptacle may be burned and destroyed.

- Make sure the battery pack is switched off, before installing it onto the wall-mounting bracket.
- Prior to installation, unpack and check the quantity and appearance of the battery and parts supplied (see page 10 for more information).
- Select the installation area (see page 12 for more information), ensure it is clear and that you have the correct tools.
- Place the wall-mounting bracket onto the appropriate area of the wall. Ensure it is level.
- Using a drill with a 14 mm drill bit (only use a drill bit that is suitable for the type of wall that you are drilling into), drill 4 M*70 mm expansion screws (not included) through the holes (indicated below in red) of the rack and into the wall (see Fig. 7 for placements).

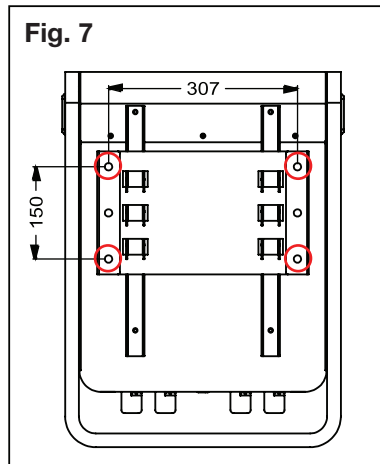

- Ensure the bracket is secured to the wall and is sturdy before attempting to hang the battery from it.
- Lift the battery (**CAREFUL! This battery is heavy!** Multiple people or specialised machinery is required) and hook the battery onto the bracket. There are six slots in the bracket which will latch on to the six “hooks” on the back of the battery
- Measure the battery voltage with a multimeter. The general factory voltage of the battery should be 51.2 V - 53.5 V.

Installation (Cont.)

- Prior to wiring, check the anode and cathode of the battery. The anode and cathode terminals should **MUST** be connected correctly.
- During battery connection, please wear protective gloves. When using metal tools, such as a torque wrench, please use insulating packaging so that the two ends of the metal tools will not make contact with the positive and negative terminals of the battery at the same time, to avoid a short-circuit.
- Before the battery is connected using the externally connected equipment, make sure that this equipment has been disconnected. Check whether the connecting polarity of the battery and total voltage are correct, then connect the battery anode with the equipment anode and battery cathode with the equipment cathode and fix the connecting line.
- During movement and installation, the battery must be handled gently. Ensure it is not dropped or impacted. The battery must not be thrown or beaten to avoid damaging the battery and creating a potential safety hazard.
- Do not touch the surface of the battery box with the sharp part of any tool to avoid scratching or damaging the battery box.
- Do not disassemble the battery box without authorization.
- Do not put any article made of metal conductive material together with the battery or assemble it into the battery box.

Startup/Shutdown Procedure

Prior to installation, please check whether the battery is functioning normally:

- Press the POWER key (Fig. 8a) at the bottom of the plate for startup, then turn on the breaker. During startup, four capacity indicator lights on the front panel (Fig. 8b), the ALM alarm (Fig. 8c) indicator light (red) and the green RUN running indicator light (Fig. 8d) will illuminate. Check whether all of these lights illuminate normally.
- After they have illuminated, the ALM alarm indicator light will go out, the RUN running indicator light will continue to illuminate, and the capacity indicator lights will illuminate to show the battery's capacity.
- If the ALM alarm indicator light flashes after startup, it means that the battery has an alarm. A newly installed battery will seldom have an alarm. The most common alarm is a battery undervoltage alarm (which results from non-use of the battery for a long time). This type of alarm will most likely stop after charging the battery for 30 seconds. If the alarm is still there after this period, please press the reset key (RST) for 10 seconds, until all LEDs light up to show that the battery has been reset. If the alarm light is no longer illuminated, the battery may be used as normal. Otherwise, contact our after sales support team.
- For shutdown after using, before pressing the POWER key, turn off the breaker.

Installation (Cont.)

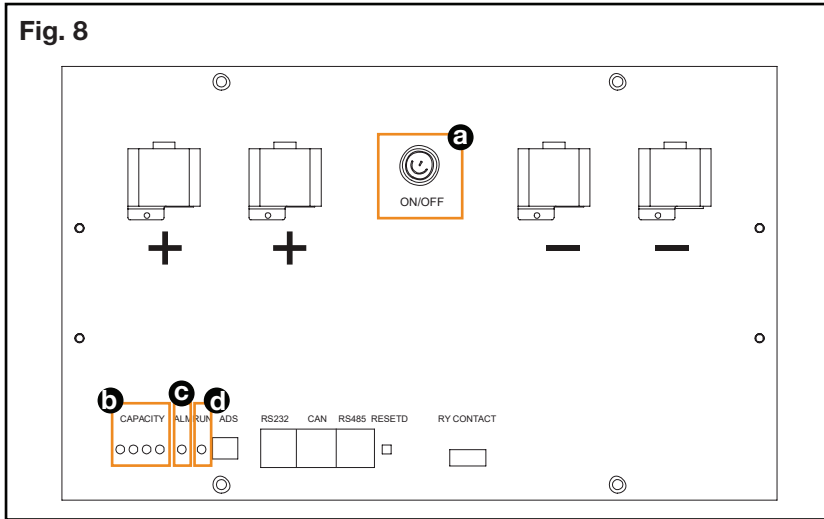

Installation of the lithium battery, wiring and startup;

- Make sure the battery pack is switched off, before installing it onto the wall-mounting bracket.
- The anode and cathode of the battery pack should be connected to the switching mode power supply or inverter.
- Please note that the switching mode power supply and inverter should be disconnected from the AC.
- Press the POWER key on one of battery packs to switch it on. This will activate any other batteries that are connected in parallel (or you can press the POWER button of each battery pack successively). The battery will then enter working mode.
- Lastly, apply AC to the power supply equipment such as switching mode power supply and inverter to make the whole standby system run.

Installation (Cont.)

Single Battery Installation

IMPORTANT!

Installation and wiring must be completed in accordance with local electrical laws and regulations. **This battery MUST be installed by a qualified professional.**

WARNING!

- Make sure the main wire is in compliance with the standard of rated capacity of the battery to avoid hazards like electric shock or fire.
- Do not use the wall receptacle as the input power source for the battery, as its rated current is less than the battery's maximum input current. Otherwise the receptacle may be burned and destroyed.

1. Ensure the POWER switch is in the OFF position before installation.
2. Turn off all connected devices before connecting to the battery.
3. Connect the following wires:

Fig. 9

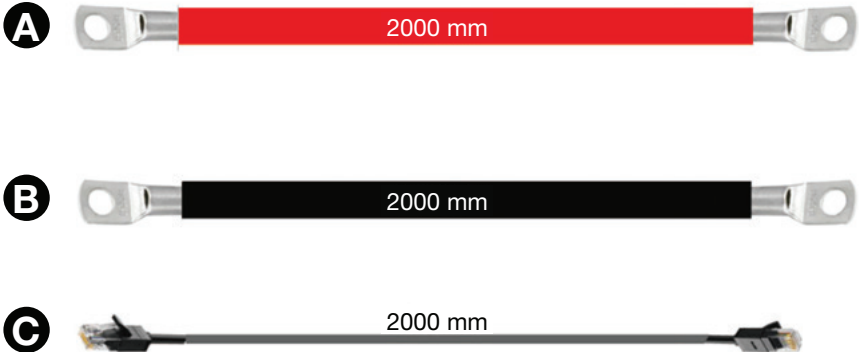

- Connect wires A and B to the switching mode power supply or inverter B+/B-.
- Connect wire C to the switching mode power supply or inverter BMS CAN/RS48.

(See Fig. 10).

Installation (Cont.)

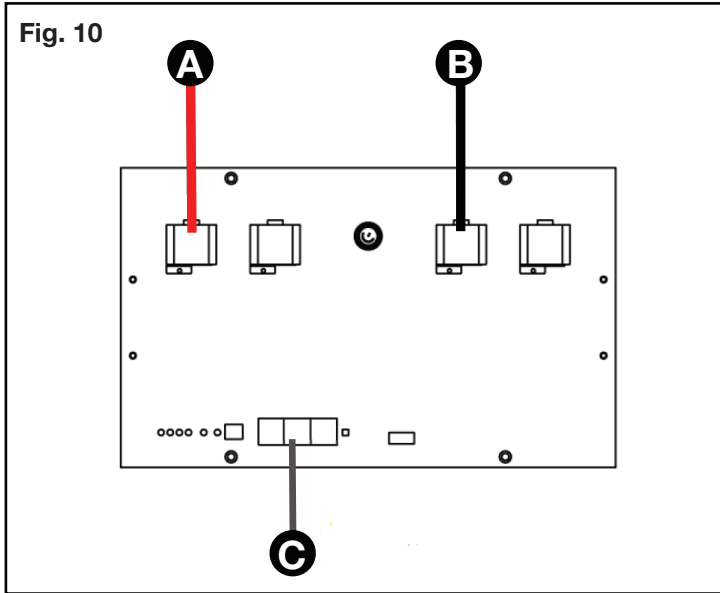

Connecting the wires

WARNING!

Ensure the power is completely switched off before installing any wires!

Failure to take the correct precautions can result in electrocution, serious injury, or death. See pages 3-5 for comprehensive safety instructions, as well as specific safety information on pages 13-14.

- To connect the wires to the battery, unscrew the plastic red or black screw cap from the positive/negative terminal.
- Remove the top plastic part from the terminal.
- Unscrew the metal nut from the bolt inside. Remove the washer beneath it.
- Place the metal loop from one end of the corresponding wire over the bolt, and attach the washer and nut back over the top, screwing them securely into the bolt, to hold the wire in place.
- Replace the top plastic part of the terminal and screw the top plastic cap over the end of the bolt.
- Please note: An overcurrent and disconnection protection device must be installed between the battery and the inverter.

Installation (Cont.)

- Connect both the positive and negative power lines of the inverter and battery, according to the setting of the circuit breaker (Fig. 11).

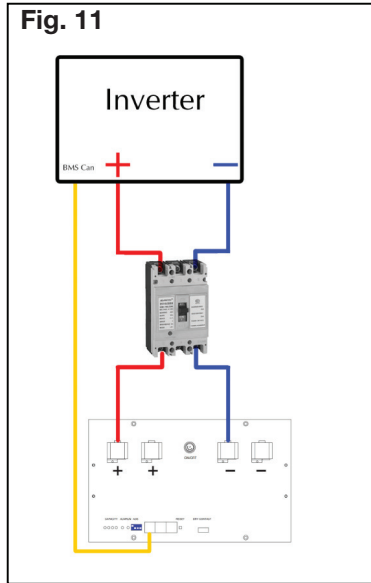

Please note, the cable from circuit breaker to inverter is not provided.

- Use the screw hole indicated on the back to install another grounding wire (Fig. 12).

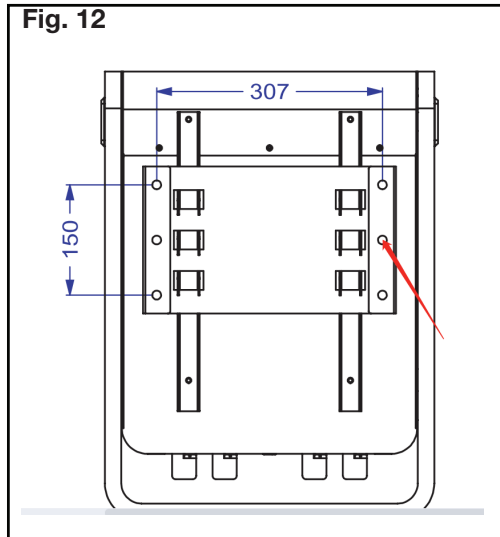

- Please note, the grounding cable is not provided.

Installation (Cont.)

Software Installation

Optionally, you can install battery monitoring software onto your computer system, to fully configure the battery monitor the battery parameters.

Installation of Battery/Batteries in Parallel

IMPORTANT!

Installation and wiring must be completed in accordance with local electrical laws and regulations. **This battery MUST be installed by a qualified professional.**

WARNING!

- Make sure the main wire is in compliance with the standard of rated capacity of the battery to avoid hazards like electric shock or fire.
- Do not use the wall receptacle as the input power source for the battery, as its rated current is less than the battery's maximum input current. Otherwise the receptacle may be burned and destroyed.

1. Ensure the POWER switch is in the OFF position before installation.
2. Turn off all connected devices before connecting to the battery.
3. Connect the following wires as indicated in the diagrams on page 20 (Fig. 14).

Fig. 13

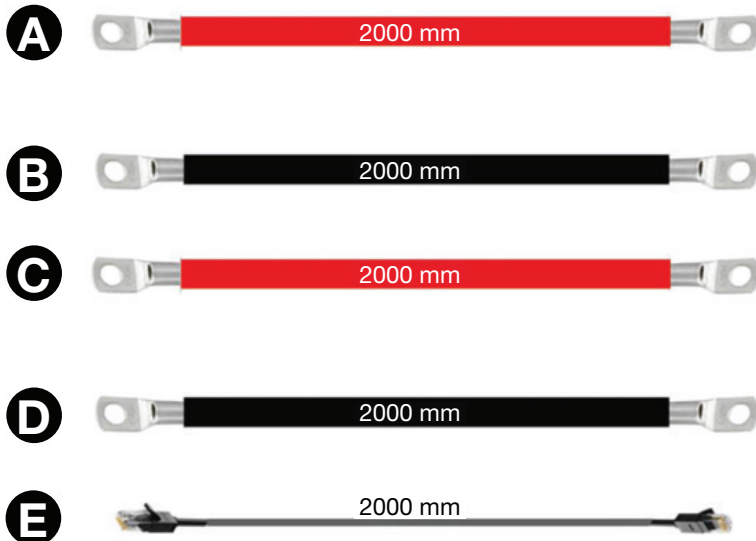

Installation (Cont.)

Fig. 14

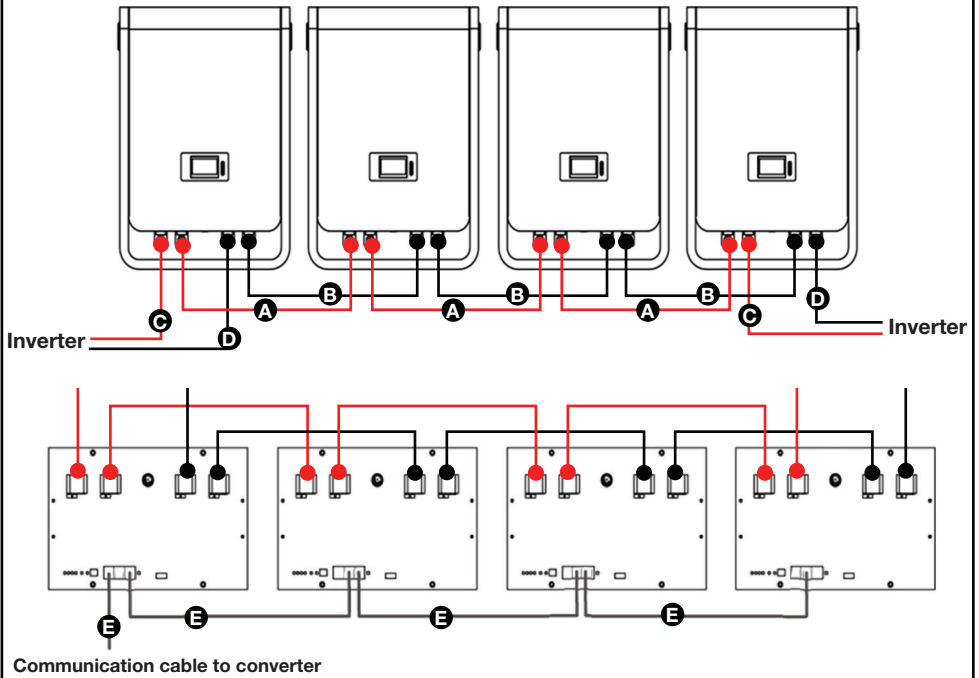

In parallel system, choose the positive power line of the inverter and last battery, according to the setting of the circuit breaker (Fig. 15). Just plug the power line in breaker.

Please note, the cable from circuit breaker to inverter is not provided.

For Australian market, to comply with AS/NZS 5139 an overcurrent protection and isolation device between each parallel battery

The BMS of each battery has the function of current monitoring, temperature monitoring, active protection and active disconnection.

Fig. 15

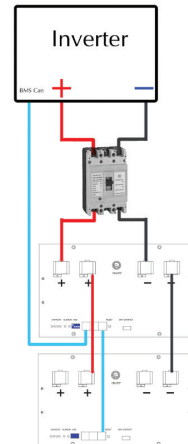

Display Interface

Using the LCD screen

1. Each option on the LCD screen begins with is ">>" or "--", where ">>" indicates the location of the cursor. Press the UP or DOWN button to move the cursor position.
2. When an option ends with ">>" it indicates that this page contains more information, which can be accessed by pressing the ENTER key when the cursor is on the corresponding page title.

For instance, in the below example (Fig. 16), the "Abnormal" and "Status" pages can be entered by moving the cursor down and pressing ENTER. Because there is not a ">>" symbol at the end of "Run mode", there is no further information on this page.

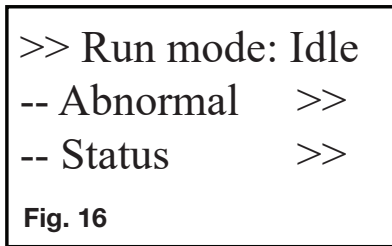

3. At any time, press the MENU button to return to the main menu.
4. For normal use, when no buttons have been pressed for one minute, the system will enter a dormant state.
5. When in a dormant state, press any key to activate the screen.

Display Interface (Cont.)

Display interface content and information

Starting the interface

After powering on, the start screen will be visible (Fig. 17). Press “MENU” to enter the display interface (Fig. 18):

Fig. 17

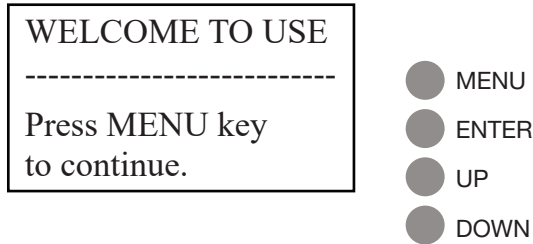
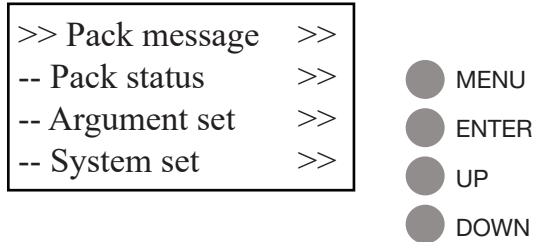

Fig. 18



Display Interface (Cont.)

Using the display Interface

The LCD display on this battery can be used to collect battery parameters. Once you have entered the main menu, you can use the “>>” cursor and the UP, DOWN and ENTER buttons select and view the parameters.

On the main menu, the options are as follows (Fig. 19):

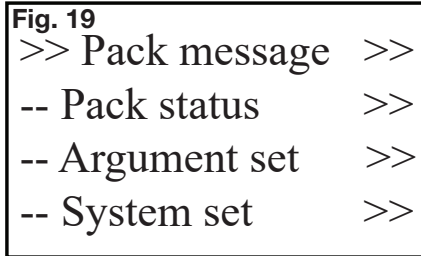

When entering the *Pack message* menu, the screen will show:

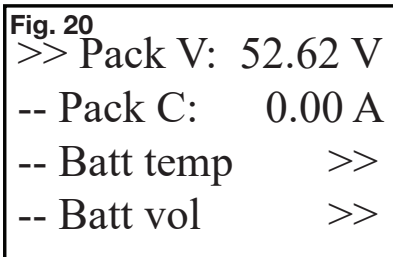

(Fig. 20 and Fig. 21)
-- Total voltage: XX.XXV
-- Current: xxxxA (discharge as “-”)
-- Battery temp
-- Battery vol
-- Battery cap

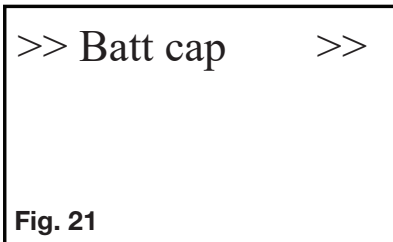

Batt temp
-- Temp1: XXX
-- Temp2: XXX
-- Temp3: XXX
-- Temp4: XXX
-- PCBtemp: XXX
-- EVtemp: XXX

NOTE: The first “X” shows “+” or “-”; The second and third “X” show the specific temperature value.

Display Interface (Cont.)

Batt vol

```
-- Vol01: xxxxmV
-- Vol02: xxxxmV
-- Vol03: xxxxmV
-- Vol04: xxxxmV
-- Vol05: xxxxmV
-- Vol06: xxxxmV
-- Vol07: xxxxmV
-- Vol08: xxxxmV
-- Vol09: xxxxmV
-- Vol10: xxxxmV
-- Vol11: xxxxmV
-- Vol12: xxxxmV
-- Vol13: xxxxmV
-- Vol14: xxxxmV
-- Vol15: xxxxmV
-- Vol16: xxxxmV
```

Batt cap

```
-- SOC: XX.XX %
-- Full capacity: XX.xxah (display actual
full capacity value)
-- Remaining capacity: XX.xxah
-- Number of cycles: XXXX
```

When entering the *Pack status* menu, the screen will show:

(Fig. 22)

```
-- Run mode: Idle
-- Abnormal
-- Status
```

Abnormal

(Fig. 20 and Fig. 21)

```
-- ShortNum: XXXX
-- TempPro: XXXX
-- OverCPro: XXXX
-- Low CPro: XXXX
-- OverVNum: XXXX
```

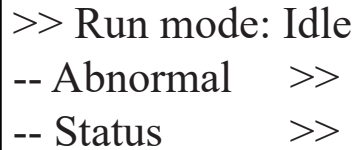

```
>> Run mode: Idle
-- Abnormal    >>
-- Status      >>
```

Fig. 22

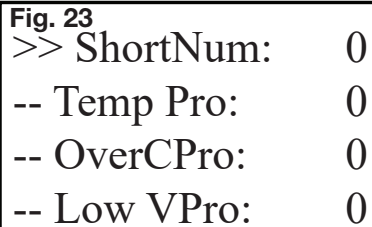

```
Fig. 23
>> ShortNum:    0
-- Temp Pro:    0
-- OverCPro:    0
-- Low VPro:    0
```



```
>> OverVNum:    0
```

Fig. 24

Display Interface (Cont.)

Status

(See Fig. 25, Fig. 26 and Fig. 27)

- HTAlarm: YES/NO
- HTPro: YES/NO
- HVAlarm: YES/NO
- HVPro: YES/NO
- LVAlarm: YES/NO
- LVPro: YES/NO
- HCArm: YES/NO
- HCPro: YES/NO
- ShorPro: YES/NO
- FailTro: YES/NO

When entering the *Argument set* menu, the screen will show:

(Fig. 28)

-- **Not manufacturer. Cannot use.**

NOTE: Non-manufacturers cannot use this section.

When entering the *System set* menu, the screen will show:

(Fig. 29)

-- Baud rate: 9600

(Temporarily unmodifiable)

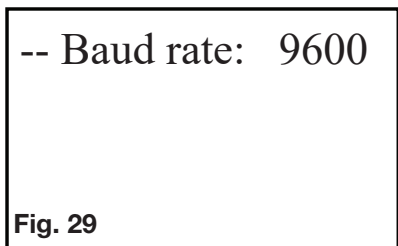
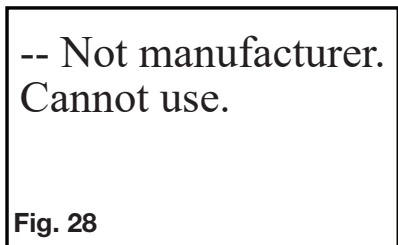
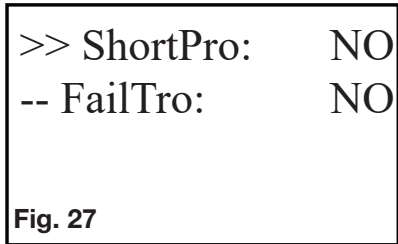
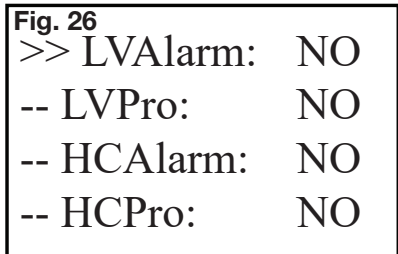
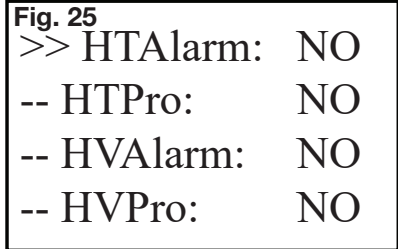

Communication Connection

Connection mode for parallel communication

When set up in parallel, the dial-up addresses of battery module are 1, 2, 3, 4.....14, and 15. “1” represents the host computer, to which other batteries’ data is uploaded; the host computer conducts unified uploading, and it is required to connect with upper computer. FF polling mode is used as consulting mode.

See Fig. 30 and Fig. 31 below for information on how to connect to your PC.

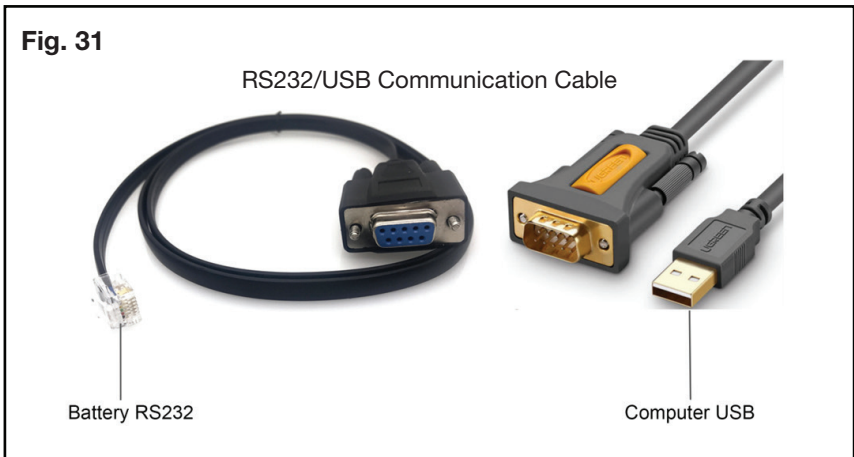
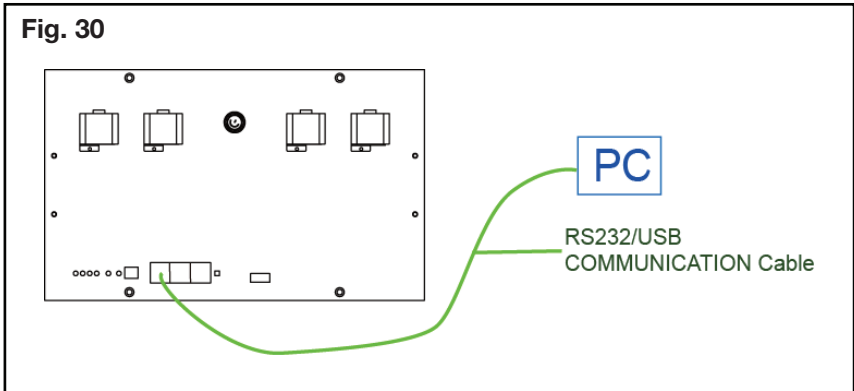

Monitoring Software Interface

Upper machine instructions

Software source file

The name of software source files are:

- *BmsTools.exe*
- *BmsTools.exe.config*
- *data*
- *Language*
- *XML*
- *DevComponents.DotNetBar2.dll*
- *NPOI.dll*

It comprises of seven documents in total.

Software running environment

The software can run on a PC using the WINDOWS operating system.

RS232 Driver

The name of the software source file is:

._PL2303_Prolific_DriverInstaller_v1180.exe._.DS_Store

Software installation and usage steps

1. Double click *._PL2303_Prolific_DriverInstaller_v1180.exe* to install.
2. Double click *BmsTools.exe* to show the main interface of the software/ Change the language to English, under the “Change Language” tab at the top right.
3. Open the main interface (as shown in Fig. 32). The software will automatically search the serial port (outlined in red) and automatically open a real-time read of the battery voltage, power, temperature, and protection of the state of battery parameters. You can select the cell using the numbers at the top of the page or by selecting from the drop-down menu at the top right (both options are outlined in the red squares in Fig. 32).
4. The operating authority is divided into general rights and administrator privileges. To make certain changes, you will need to enter the administrator password (Fig. 32) (circled in red):
kyhtbms

Monitoring Software Interface (Cont.)

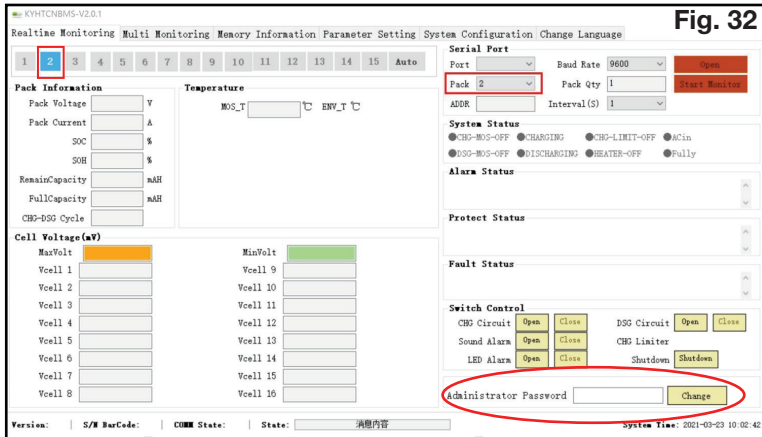

5. Under the “Realtime Monitoring” tab (Fig. 33) you can view a real-time display of the various battery parameters.

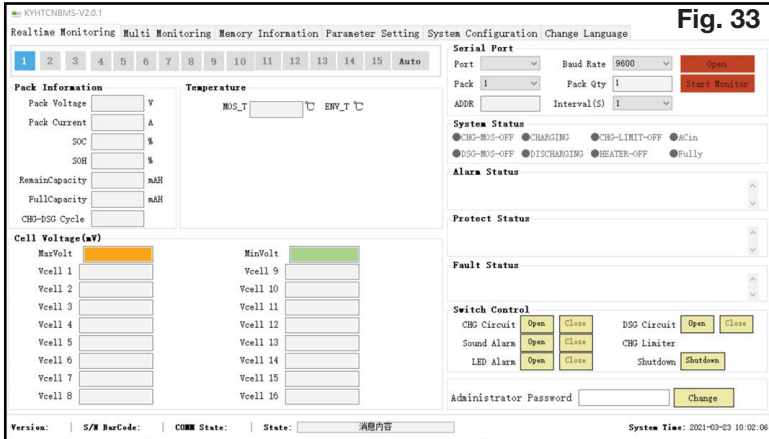

Monitoring Software Interface (Cont.)

6. Enter the “Multi Monitoring” tab (Fig. 34) to select the automatic storage option (“Autosave”). This will automatically store the battery parameters in an excel table. This file can be found (in the software) under the current file path of the data folder. The storage file will be named after pack number and time. For example: *packNo1_20150306145010.xls*.

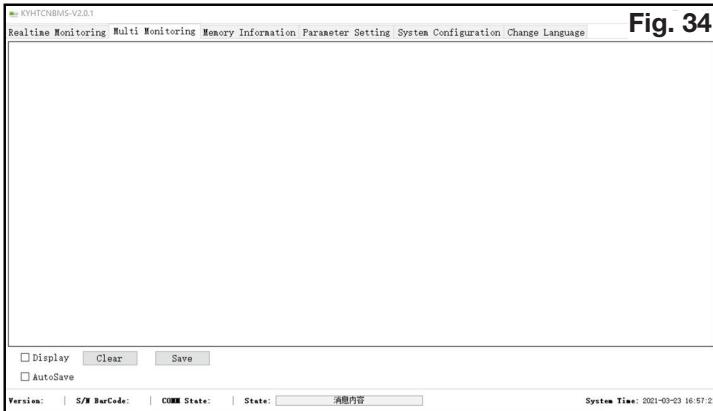

Fig. 34

7. Under the “Memory Information” tab (Fig. 35), you can read the battery protective plate records. These include the protection, alarm, restoration of the category, and time of occurrence records, as well as fault categories and fault occurrences of monomer voltage, total voltage, charge/discharge capacity, charge/discharge current, temperature, etc. This is in addition to normal record protection and alarm and recovery information, but can be found by setting the following battery parameters within a certain period of time: monomer voltage, total voltage, charge/discharge capacity, charge/discharge current, temperature, etc.

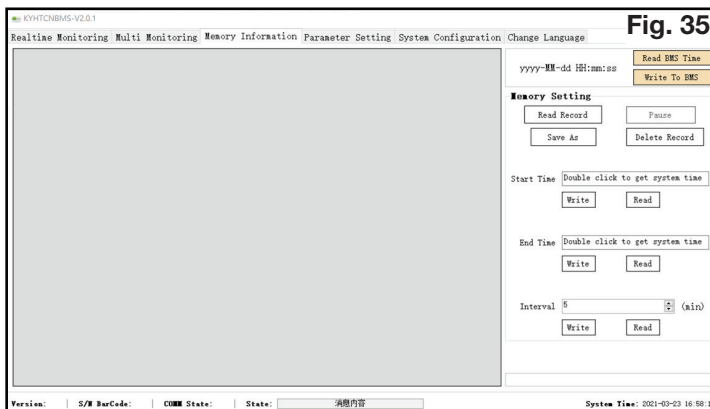
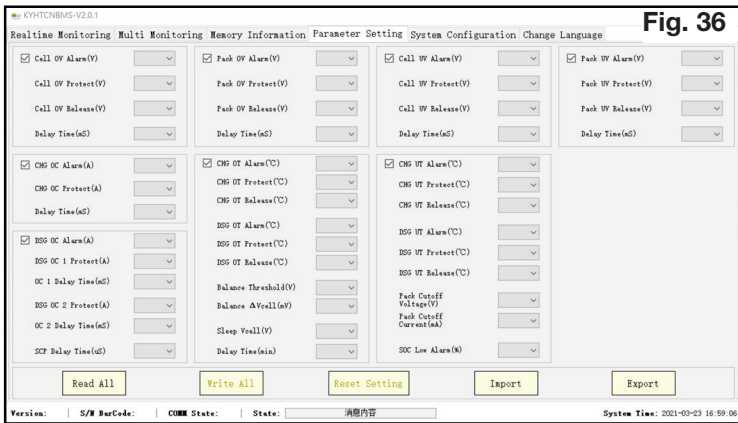

Fig. 35

Monitoring Software Interface (Cont.)

8. Under the “Parameter Setting” tab (Fig. 36), you can view the battery parameters, including:

- Reading the parameters
- Writing the parameters
- Restoring the default parameters for the battery
- Importing the parameters (in an XML file format)
- Exporting the parameters (from the import file format for the XML to the current tab)



9. In the system configuration tab (Fig. 37), you can calibrate the battery and set battery calibration parameters. To do so, you will need administrator privileges.

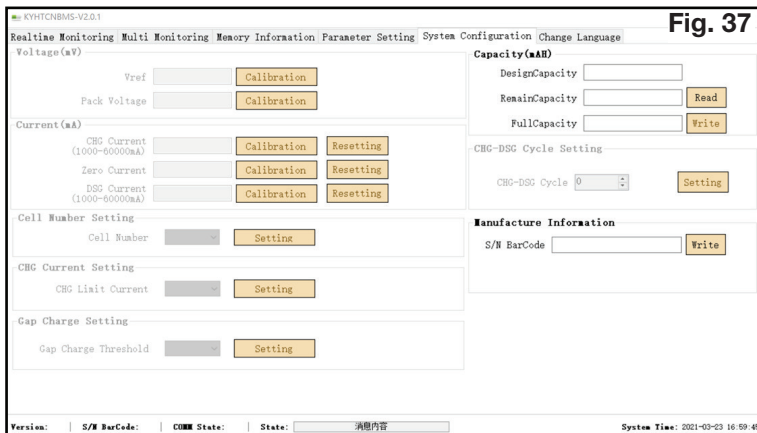

Equipment Interface Instructions

Address Switch Function (only in parallel)

When the batteries are set up to work in parallel, the host/client pack and server packs need to be addressed as follows:

| | Dial code switch position | | | | Instruction |
|----|---------------------------|-----|-----|-----|----------------------------|
| | #1 | #2 | #3 | #4 | |
| 0 | OFF | OFF | OFF | OFF | No cascade, use single |
| 1 | ON | OFF | OFF | OFF | Set to Pack1 (Host/Client) |
| 2 | OFF | ON | OFF | OFF | Set to Pack2 |
| 3 | OFF | OFF | ON | OFF | Set to Pack3 |
| 4 | OFF | OFF | OFF | ON | Set to Pack4 |
| 5 | ON | OFF | ON | OFF | Set to Pack5 |
| 6 | OFF | ON | ON | OFF | Set to Pack6 |
| 7 | ON | ON | ON | OFF | Set to Pack7 |
| 8 | OFF | OFF | OFF | ON | Set to Pack8 |
| 9 | ON | OFF | OFF | ON | Set to Pack9 |
| 10 | OFF | ON | OFF | ON | Set to Pack10 |
| 11 | ON | ON | OFF | ON | Set to Pack11 |
| 12 | OFF | OFF | ON | ON | Set to Pack12 |
| 13 | ON | OFF | ON | ON | Set to Pack13 |
| 14 | OFF | ON | ON | ON | Set to Pack14 |
| 15 | ON | ON | ON | ON | Set to Pack15 |

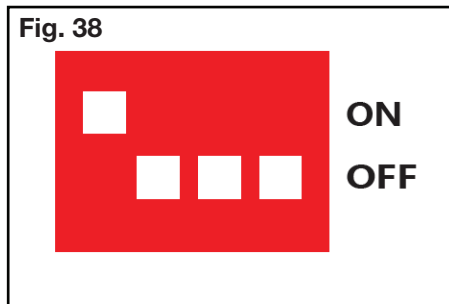

Equipment Interface Instructions (Cont.)

Communication Function

RS485/CAN Communication Port Definition (RJ45 Port Pin) (Fig. 39):

| No. | RJ45 PIN |
|------|----------|
| 1, 8 | RS485-B |
| 2, 7 | RS485-A |
| 3, 6 | GND |
| 4 | CAN-H |
| 5 | CAN-L |

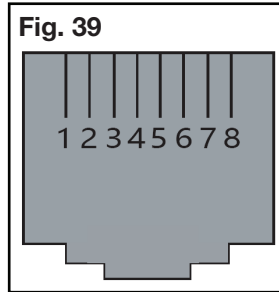

RS485/CAN Communication Port Definition (RJ11 Port Pin) (Fig. 40):

| No. | RJ11 PIN |
|---------|------------------|
| 1, 2, 6 | NC |
| 3 | TX (Single face) |
| 4 | RX (Single face) |
| 5 | GND |

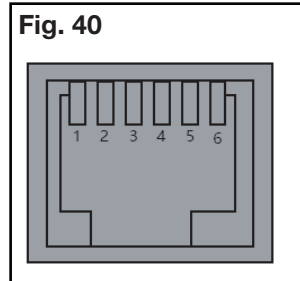

Operations

LED Indicators:

| State | Nominal/Warning/ Protection | RUN | ALM | Power indicator LED | | | Instruction |
|-----------|--|---------|---------|------------------------|-----|-----|---|
| | | | | ● | ● | ● | |
| Shut down | Dormancy | OFF | OFF | OFF | OFF | OFF | All OFF |
| Standby | Nominal | Flash 1 | OFF | Follow module capacity | | | Standby |
| | Warning | Flash 1 | Flash 3 | | | | Module at low voltage |
| Charge | Nominal | ON | OFF | Follow module capacity | | | LED flash 2 at full capacity, ALM doesn't flash at overcharge warning |
| | Warning | ON | Flash 3 | | | | |
| | Overcharge protection | ON | OFF | ON | ON | ON | If there is no grid supply, the LED turn to standby |
| | Temperature, disabled protection | OFF | ON | OFF | OFF | OFF | Stop charging |
| Discharge | Nominal | Flash 3 | OFF | Follow module capacity | | | Stop discharging |
| | Warning | Flash 3 | Flash 3 | | | | |
| | Under voltage protection | OFF | OFF | OFF | OFF | OFF | Stop discharging |
| Disabled | Temperature, overcurrent, short circuit, reverse connect disabled protection | OFF | OFF | OFF | OFF | OFF | Stop discharging |
| | | OFF | OFF | OFF | OFF | OFF | Stop charging and discharge |

NOTE: Flash 1: light 0.25 s / off 3.75 seconds; Flash 2: light 0.5 s / off 0.5 s; Flash 3: light 0.5 s / off 1.5 s

Operations (Cont.)

Reset Key Function

| Mode | Press and Hold Time | | |
|------------|----------------------|------------------------|------------|
| | 0-3 seconds | 3-6 seconds | >6 seconds |
| Normal | Indication by SOC | Transfer to Sleep Mode | Reset |
| Sleep Mode | Wake from Sleep Mode | | |

Using the LCD screen

For a detailed explanation of how to operate the LCD screen, see pages 21-25.

Troubleshooting

If the system is not operating correctly, please see the table below for troubleshooting options.

| Issue | Possible Cause | Solution |
|---|--|---|
| No indicator or alarm on the front display panel | Sleep mode | Press “Reset” to enter normal operation mode |
| No indicator or alarm on the front display panel even after resetting | Battery voltage too low | Charge battery immediately |
| Red LED flashing when in standby mode | Battery cell low voltage | Charge battery immediately |
| Red LED flashing when charging | Alarm indicating protection when charging | Check the BMS for the alarm, then check the charge voltage and current (see page 29). |
| Red LED flashing when discharging | The battery power is too low and will shutdown | Charge battery immediately |
| RED LED illuminating continuously | There is a problem with the internal workings of the battery | Contact our after sales support team |

The specific nature of any other issues with this product can also be determined based on the following variables:

1. Whether the battery can be switched on.
2. If the battery can be switched on, check if the red alarm light the red light is off, flashing or on.
3. If the red light is off, check whether the battery can be charged/discharged.

Preliminary determination steps:

If the battery cannot be turned on, and lights are all not flashing or illuminated, ensure the external switch is ON. If it is ON, the RUN light is flashing, the external power supply voltage is 51.2 V (or greater), and the battery is still unable to turn on, please contact our after sales support team (see bottom of the page).

If the battery can be turned on, but the red light is illuminated, and the battery cannot be charged or discharged, the system is abnormal - please check the following:

- **Temperature:** If the temperature is above 50 °C or under -10 °C, the battery will not function. Please move the battery to a location that is in the normal operating temperature range (between -10 °C and 50 °C).

Troubleshooting (Cont.)

- **Current:** If current is larger than 100 A, battery protection will turn on. To fix this, check whether current is over this limit. If it is, change the settings on the power supply side.
- **High Voltage:** If the charging voltage is above 58.4 V, the battery protection will turn on. To fix this, check whether the voltage is over this limit. If it is, change the settings on the power supply side.
- **Low Voltage:** When the battery discharges to 40 V or less, the battery protection will turn on. To fix this, charge the battery until red light turns off.

If the battery still cannot be charged or discharged, please see below:

- **Cannot be charged:** Disconnect the power cables and measure the voltage on the power side. If the voltage is 56.5~57.6 V, restart the battery, connect the power cable and try again.
- **Cannot be discharged:** Disconnect the power cables and measure voltage on the battery side. If it is under 40 V, please charge the battery. If the voltage is above 51.2 V and still cannot discharge, turn off the battery and contact our after sales support team.

If the fault is still cannot be located or fixed, turn off battery and contact after sales support.

Emergency Scenarios

Leaking Batteries: If the battery pack leaks electrolyte, avoid contact with the leaking liquid or gas. If you are exposed via:

- **Inhalation:** Evacuate the contaminated area and seek medical attention.
- **Contact with eyes:** Rinse eyes with flowing water for 15 minutes and seek medical attention.
- **Contact with skin:** Wash the affected area thoroughly with soap and water and seek medical attention.
- **Ingestion:** Seek medical attention.

Fire: DO NOT EXTINGUISH THE BURNING BATTERY WITH WATER! Only use a Hfc-227ea fire extinguisher.

Wet Batteries: If the battery pack is wet or submerged in water, evacuate the area and contact emergency services or an authorized dealer for technical support.

Damaged Batteries: Damaged batteries are dangerous and must be handled with the utmost care. They are not fit for use and may pose a danger to people or property. If the battery pack seems to be damaged, pack it in its original container, and the return it to an authorized dealer.

If none of these options diagnose or fix the issue, please contact our after sales support team at tempo.org/support or on 1300 886 605.

Maintenance

Storage

Before storing this battery, charge it at for least 7 hours. Store the battery covered and upright in a cool, dry location. The recommend long-term storage temperature is 15 °C - 25 °C.

During storage, recharge the battery every 3 months for 1-2 hours (assuming a storage temperature of 0 °C- 40 °C). This is to avoid damaging the battery.

Maintenance

- **WARNING!** The battery system operates with hazardous voltages. Repairs may be carried out only by qualified maintenance personnel.
- **DANGER!** Even after the unit is disconnected from the mains, components inside are still connected to the battery cells which are potentially dangerous.
- **WARNING!** Before carrying out any kind of service and/or maintenance, disconnect the batteries and verify that no current is present and no hazardous voltage exists in the terminals.
- **WARNING!** Only persons are adequately familiar with batteries and with the required precautionary measures may replace batteries and supervise operations. Unauthorized persons must be kept well away from the batteries.
- **DANGER!** Verify that no voltage between the battery terminals and the ground is present before maintenance or repair. In this product, the battery circuit is not isolated from the input voltage. Hazardous voltages may occur between the battery terminals and the ground.
- **WARNING!** Batteries may cause electric shock and have a high short-circuit current. Please remove all wristwatches, rings and other metal personal objects before maintenance or repair, and only use tools with insulated grips and handles for maintaining or repairing.
- **WARNING!** When replace the batteries, install the same number and same type of batteries.
- **WARNING!** When replace the parallel batteries, make sure the new battery is full charged.
- **WARNING!** Do not open or destroy batteries. Escaping electrolyte can cause injury to the skin and eyes. It may be toxic.
- **WARNING!** Please replace the fuse only with the same type and amperage in order to avoid fire hazards.
- **WARNING!** Do not disassemble the battery system.

Daily inspection items

- Check whether the battery data is normal and whether there is abnormal alarm through the battery display screen
- Check whether the battery warning lamp is abnormal on site
- Check whether the connecting system is loose

Maintenance (Cont.)

Monthly inspection items

- Repeat daily inspection items.
- Check whether the surface of connecting terminal and connecting strip is clean; Whether there is damage, deformation or corrosion, and avoid using connecting parts with serious oxidation corrosion and dirt for installation.
- Whether the connecting wires at the battery connection and the main output busbar are loose, and whether the battery connection is reverse polarity or short circuit.
- Does the battery show signs of smoke or burning.
- Check whether the exterior of the battery case is deformed.
- Whether the battery has liquid seepage or pungent smell.

Other Useful Information

Technical Parameters of the Battery Management System (BMS)

| Function name | Item list | Set value | Setting range |
|-----------------------------------|----------------------------------|--|---|
| Monomer voltage alarm | Overvoltage alarm voltage | 3600 ± 20 mV | Alarm value of monomer undervoltage to 4500 mV |
| | Undervoltage alarm voltage | 2800 ± 50 mV | 1000 mV to alarm value of monomer overvoltage |
| Monomer overvoltage protection | Overvoltage protection voltage | 3700 ± 20 mV | Recovery value of monomer overvoltage to 4500 mV |
| | Overvoltage recovery voltage | 3400 ± 20 mV | Recovery value of monomer undervoltage to protection value of monomer overvoltage |
| | Overvoltage recovery conditions | <ol style="list-style-type: none"> When the monomer voltage is lower than the recovery point, automatically recover charging. When the monomer voltage is lower than the protection point and the capacity is ≤95% (regularly charging conditions: charging once per day), recover charging. | |
| Monomer undervoltage protection | Undervoltage protection voltage | 2500 ± 50 mV | 1000 mV to recovery value of monomer undervoltage |
| | Undervoltage recovery voltage | 2700 ± 50 mV | Protection value of monomer undervoltage to Recovery value of monomer overvoltage |
| | Undervoltage recovery conditions | The valid charging current is detected and the voltage is higher than the recovery point. | |
| Alarm of total voltage of battery | Overvoltage alarm voltage | 57.6 ± 0.3 V | Alarm value of total voltage undervoltage to 65 V |
| | Undervoltage alarm voltage | 44.8 ± 0.5 V | 20 V to alarm value of total voltage overvoltage |

Other Useful Information (Cont.)

| | | | |
|---------------------------------|--|--|---|
| Battery overvoltage protection | Overvoltage protection voltage | $59.2 \pm 0.3 \text{ V}$ | Recovery value of total voltage overvoltage to 65 V |
| | Overvoltage recovery voltage | $54.4 \pm 0.3 \text{ V}$ | Recovery value of total voltage undervoltage to protection value of total voltage overvoltage |
| | Overvoltage recovery conditions | <ol style="list-style-type: none"> When the total voltage is lower than the recovery point, automatically recover charging. When the total voltage is lower than the protection point and the capacity is $\leq 95\%$ (regularly charging conditions: charging once per day), recover charging. | |
| | Floating charge voltage | $56 \pm 0.5 \text{ V}$ | |
| Battery undervoltage protection | Undervoltage protection voltage | $41.6 \pm 0.5 \text{ V}$ | 20 V to recovery value of total voltage undervoltage |
| | Undervoltage recovery voltage | $44.8 \pm 0.5 \text{ V}$ | Protection value of total voltage undervoltage to recovery value of total voltage overvoltage |
| | Undervoltage recovery conditions | The valid charging current is detected and the voltage is higher than the recovery point. | |
| Battery cell temperature alarm | High temperature alarm of battery cell | $55 \pm 3 \text{ }^\circ\text{C}$ | Low temperature alarm value of battery cell to $90 \text{ }^\circ\text{C}$ |
| | Low temperature alarm of battery cell | $0 \pm 3 \text{ }^\circ\text{C}$ | $-40 \text{ }^\circ\text{C}$ to high temperature alarm value of battery cell |

Other Useful Information (Cont.)

| | | | |
|---|---|--------------------------------------|---|
| No charging due to temperature of the battery cell | Charging high temperature protection | $60 \pm 3 \text{ }^{\circ}\text{C}$ | Recovery value of charging high temperature to $90 \text{ }^{\circ}\text{C}$ |
| | Charging high temperature recovery | $50 \pm 3 \text{ }^{\circ}\text{C}$ | Recovery value of charging low temperature to protection value of charging high temperature |
| | Charging low temperature protection | $-5 \pm 3 \text{ }^{\circ}\text{C}$ | $-40 \text{ }^{\circ}\text{C}$ to recovery value of charging low temperature |
| | Charging low temperature recovery | $0 \pm 3 \text{ }^{\circ}\text{C}$ | Protection value of charging low temperature to recovery value of charging high temperature |
| No discharging due to temperature of the battery cell | Discharging high temperature protection | $65 \pm 3 \text{ }^{\circ}\text{C}$ | Recovery value of discharging high temperature to $90 \text{ }^{\circ}\text{C}$ |
| | Discharging high temperature recovery | $50 \pm 3 \text{ }^{\circ}\text{C}$ | Recovery value of discharging low temperature to protection value of discharging high temperature |
| | Discharging low temperature protection | $-20 \pm 3 \text{ }^{\circ}\text{C}$ | $-40 \text{ }^{\circ}\text{C}$ to recovery value of discharging low temperature |
| | Discharging low temperature recovery | $0 \pm 3 \text{ }^{\circ}\text{C}$ | Protection value of discharging low temperature to recovery value of discharging high temperature |

Other Useful Information (Cont.)

| | | | |
|---------------------------------|--|------------------------------------|---|
| Ambient temperature alarm | High ambient temperature alarm | $65 \pm 3 \text{ }^\circ\text{C}$ | Alarm value of low ambient temperature to $90 \text{ }^\circ\text{C}$ |
| | Low ambient temperature alarm | $-10 \pm 3 \text{ }^\circ\text{C}$ | $-40 \text{ }^\circ\text{C}$ to alarm value of high ambient temperature |
| BMS temperature protection | MOS-Over-Temperature Alarm ($^\circ\text{C}$) | $90 \pm 3 \text{ }^\circ\text{C}$ | Recovery value of MOS high temperature to $90 \text{ }^\circ\text{C}$ |
| | MOS-Over-Temperature Protection ($^\circ\text{C}$) | $115 \pm 3 \text{ }^\circ\text{C}$ | $-40 \text{ }^\circ\text{C}$ to high temperature alarm value of battery cell |
| | MOS-Over-Temperature Protection Release ($^\circ\text{C}$) | $85 \pm 3 \text{ }^\circ\text{C}$ | Recovery value of charging low temperature to protection value of charging high temperature |
| Ambient temperature protection | High ambient temperature protection | $70 \pm 3 \text{ }^\circ\text{C}$ | Recovery value of high ambient temperature to $90 \text{ }^\circ\text{C}$ |
| | High ambient temperature recovery | $50 \pm 3 \text{ }^\circ\text{C}$ | Recovery value of low ambient temperature to protection value of high ambient temperature |
| | Low ambient temperature protection | $-20 \pm 3 \text{ }^\circ\text{C}$ | $-40 \text{ }^\circ\text{C}$ to recovery value of low ambient temperature |
| | Low ambient temperature recovery | $0 \pm 3 \text{ }^\circ\text{C}$ | Protection value of low ambient temperature to recovery value of high ambient temperature |
| Charging overcurrent alarm | Charging alarm current | $55 \pm 1 \text{ A}$ | 3 A to protection value of charging overcurrent |
| Charging overcurrent protection | Charging protection current | $60 \pm 1 \text{ A}$ | Alarm value of charging current to 60 A |

Other Useful Information (Cont.)

| | | | |
|------------------------------------|--|--|---|
| Charging current limiting function | Charging limiting current | 10 A | It may be set to be 0, i.e. close the charging current limiting function. |
| Discharging overcurrent alarm | Discharging alarm current | 110 ± 1 A | Protection value of discharging overcurrent to 3 A |
| Discharging overcurrent protection | Discharging protection current | 130 ± 1 A | 130 A to alarm value of discharging current |
| Output short-circuit protection | Short-circuit protection current | 350 A | 300 μ s (can be adjusted) |
| | Short-circuit protection locking | Continuous output short circuit and exceed the overcurrent locking times | |
| | Short-circuit unlocking | Continuous charger | |
| Automatic recovery of overcurrent | 60 s | 1 s to 60 s | |
| Sustainable voltage | 100 V $\overline{=}$ | 10 s | |
| Continuous overcurrent locking | The overcurrent event with the time interval of no more than 5 minutes is called continuous overcurrent. | | |
| | 3 times | 1 to 100 times | |

Other Useful Information (Cont.)

| | | | |
|--------------------------------------|---|--|---|
| Equilibrium function of battery cell | Charging equilibrium of battery cell | Cut-in conditions: State of valid charging current | |
| | Equilibrium cut-in voltage | 3450 mV | 3000 mV to 4500 mV |
| | Voltage difference of equilibrium cut-in | 50 mV | Voltage difference value after equilibrium to 100 mV |
| | Voltage difference after equilibrium | 30 mV | 10 mV to voltage difference value of equilibrium cut-in |
| | Equilibrium current | 80 mA | |
| | Equilibrium high temperature prohibition | 50 °C | Prohibition value of equilibrium low temperature to 70 °C |
| | Equilibrium low temperature prohibition | 0 °C | -20 °C to prohibition value of equilibrium high temperature |
| | Static equilibrium of battery cell | Cut-in conditions: All non-discharging states | |
| | Estimate based on the voltage of the battery cell | | |
| | After over voltage protection, when the rest capacity of the battery is reduced to 95% below or meets the regular charging conditions (charging once per day), recover charging if the voltage is lower than the over voltage protection setting point. | | |
| Manual key setting | In the shutdown state of BMS, press the key for 1 s for startup. | | |
| BMS power consumption management | Maximum standby time: 4 h (the AC does not discharge, without valid discharging current). | | |
| Power consumption of normal running | <30 mA | | |
| Static total power consumption | Max. 150 μA | Type 100 μA | |

Other Useful Information (Cont.)

Service, repair and spare parts

CAUTION!

If your battery appears not to be operating correctly, contact our after sales support centre for advice. Do not attempt to repair the appliance yourself!

Please note that if you book a service, the appliance must be accessible for the technician to perform any necessary repair. If the battery is installed in such a way that the technician is concerned that damage will be caused to the appliance or your property, then they will not complete a repair.

This appliance must only be serviced by authorised personnel.

There are no spare parts available for purchase.

Other Useful Information (Cont.)

Battery Pack Technical Specifications

| Model Number | AKE-5KW-HB |
|--|--|
| Nominal voltage | 51.2 V |
| Rated capacity | 100 Ah |
| Rated reserved energy | 5120 Wh |
| Standard charging current | 0.3 C |
| Maximum continuous charging current | 0.5 C |
| Minimum continuous charging current | 0.1 C |
| Total charging cut-off voltage | 58.4 V |
| Cut-off voltage of charging monomer | 3.65 V |
| Standard discharging current | 0.5 C |
| Maximum continuous discharging current | 1 C |
| Cut-off voltage of discharging monomer | 2.5 V |
| Charging temperature range | -10°C ~ 50 °C |
| Discharging temperature range | -20 °C ~ 45 °C |
| Dimension (W×D×H) | 445 x 197 x 610 mm |
| Weight | 52.68 kg |
| Ingress Protection Rating | IP65 |
| External DC Isolator | Min. 120 A |
| Power Consumption | <2 W (Work), <100 mW (Sleep) |
| Storage temperature | -20°C ~ 45°C |
| Communication Interface | CAN/RS-485/RS-232 |
| Differential pressure | Differential pressure at the discharging end (2.5 V for monomer) ≤300 mV |
| | Differential pressure at the charging end (3.65 V for monomer) ≤300 mV |

Other Useful Information (Cont.)

Compliance

This appliance has been fully tested and meets all requirements as set out by standards AS IEC 62619 & AS/NZS 62368.



The RCM Mark (Regulatory Compliance Mark) indicates that the product complies with the relevant guidelines of the ACMA as well as corresponding government requirements for the safety of electrical devices.

Responsible disposal



Packaging materials are recyclable. Please dispose of them responsibly for recycling.



At the end of its working life, do not throw this appliance out with your household waste. Electrical and electronic products contain substances that can have a detrimental effect on the environment and human health if disposed of inappropriately. Observe any local regulations regarding the disposal of electrical consumer goods and dispose of it appropriately for recycling.

Contact your local authorities for advice on recycling facilities in your area. Or find recycling scheme services listed on Planet Ark's website at www.recyclingnearyou.com.au, or call Planet Ark on 1300 733 712.

Other Useful Information (Cont.)

Licensed installer/electrician details

Please ask your licensed installer/electrician to fill in the details below so you have them on record should you need to contact the installer in the future.

Proof of professional installation is also required for warranty claims.

Please fill in the details below:

Name of licensed installer:

Licence number:

Date of installation:

Signature:

Installer Notes

Installer Notes (Cont.)

Installer Notes (Cont.)

Warranty returns

Should you for any reason need to return this product for a warranty claim, make sure to include all accessories with the product.

Product does not work?

If you encounter problems with this product, or if it fails to perform to your expectations, make sure to contact our After Sales Support Centre on (AU) 1300 886 605 for advice.

For an electronic copy of this manual, please contact our after sales support centre.

Distributed by Tempo (Aust) Pty Ltd ABN 70 106 100 252

PO BOX 132, Frenchs Forest NSW 1640, Australia

Customer Helpline:

(AU) 1300 886 605

Web Support: tempo.org/support

IM Version No: V1.0

Issue: October 2022

After Sales Support

☎ 1300 886 605 (AUS) | 🌐 tempo.org/support